

ALUMINUM
WINDOWS

T8700HW Series

4" Thermally-Broken Projected Heavy Wall Window



The D8 Aluminum T8700HW Series Thermally-Broken Projected Heavy Wall Window provides exceptional value and performance while enhancing the views of schools, hospitals, public buildings or any commercial application. This system is engineered to meet DOD/GSA blast criteria and ASTM criteria for hurricane-rated systems. It has been tested in accordance with AAMA/WDMA/CSA/101/I.S.2/A440-08 (NAFS-08).

The T8700HW Series is a pressure equalized, precision manufactured window system designed for energy conservation and demanding performance requirements. The aluminum extrusions accept poured-in debridged polyurethane thermal break materials when specified. It offers a complete thermal break separation which reduces thermal conductance and increases energy efficiency. Inside or outside glazing with single or double-glazed IGUs, as required.

The T8700HW Series Thermally-Broken Projected Heavy Wall Window comes in a wide variety of custom painted and anodized finishes. It also comes with an industry standard factory warranty.

FEATURES	RESULTS
Aluminum system	Sleek profile, long-lasting strength and durability
Blast rated	Engineered to meet DOD/GSA blast criteria
Hurricane rated	Engineered to meet ASTM 1886/ASTM 1996
4" depth	Delivers structural integrity to accommodate design requirements
Heavy wall	Design flexibility to accommodate increased size and performance requirements
Casement, awning and fixed configurations	Configurable options to accommodate design specifications
Head/jamb compensation channel	Installation options plus accommodates slab deflection and is ideal for window replacement
Sub-sill	Installation options/performance
Vertical stack mullion option	Ribbon together at installation
Factory glazed	Consistent, reliable performance and excellent quality control
4-bar hinge	Smooth operation and stability
Optional screens	Insect deterrent
Custom painted and anodized finishes	Wide variety of finishes to accommodate design specifications and customer needs

ALUMINUM
WINDOWS

T8700HW Series

4" Thermally-Broken Projected Heavy Wall Window

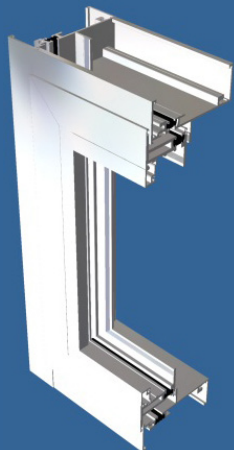
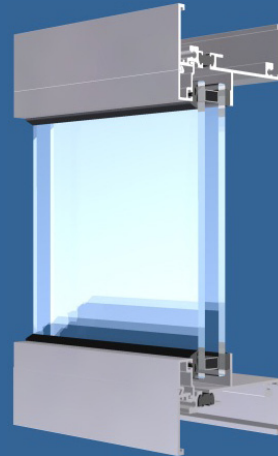
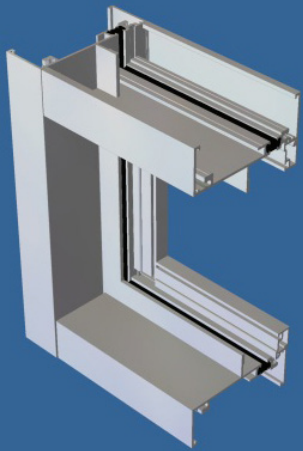

PERFORMANCE DATA

Type	Fixed	Awning	Casement
Air @ 6.24 PSF Per ASTM E-283	<0.1 cfm/SF	0.01 cfm/SF	0.01 cfm/SF
Water Per ASTM E-331	15 psf	12 psf	12 psf
U-Value Per NFRC-100	0.29 - 0.48	0.36 - 0.55	0.36 - 0.55

