



2" X 4 1/2" NON THERMAL, 1" CENTER GLAZED

1. General Description.

Work included: The glazing contractor shall furnish all necessary labor, materials and equipment for the complete installation of aluminum framing called for in the contract documents.

Drawings and Specifications are based on Pacific Aluminum Series 700 Non-Thermal storefront, center glazed for 1" glass.

2. Materials.

Extrusions shall be 6063-T5 alloy and temper. Fasteners, where exposed will be aluminum, stainless steel or other non-corrosive material. Perimeter anchors shall be cadmium plated steel. Glazing gaskets shall be E.P.D.M. extrusion.

3. Performance Requirements.

Air Infiltration: System shall be tested in accordance with ASTM E283. Infiltration shall not exceed .06 CFM per square foot of fixed area when tested at 6.24 P.S.F.

Water Infiltration: System shall be tested in accordance with ASTM E331. No water penetration shall occur at a test pressure of 10 P.S.F.

Structural Performance: System shall be tested in accordance with ASTM E330. Maximum deflection shall be 1/175 of span at a wind load of _____ P.S.F. (Architect specify wind load)

5. Finish.

All exposed surfaces shall be free of scratches and other serious blemishes. Finish shall be manufacturers standard _____ (Clear anodized, Bronze anodized or White polyester paint) or custom painted _____. (select one)
(Architect to provide color and specification)

6. Fabrication

The framing system shall be flush glazed on all sides with no projecting glazing stops. Entrance framing shall be compatible with glass framing. System shall provide for internal water drainage into an aluminum sub sill that drains to the exterior through weep holes.

7. Installation.

Storefront framing shall be installed in their correct locations and set level, square and plumb in alignment with other work and substrates, in accordance with the manufacturers installation instructions, approved shop drawings and accepted industry standards. All joints between framing and substrates shall be sealed per sealant manufacturers recommendations to insure a weather tight installation.

8. Protection and cleaning.

After installation the General Contractor shall protect exposed aluminum surfaces from damage. The General Contractor shall be responsible for final cleaning.

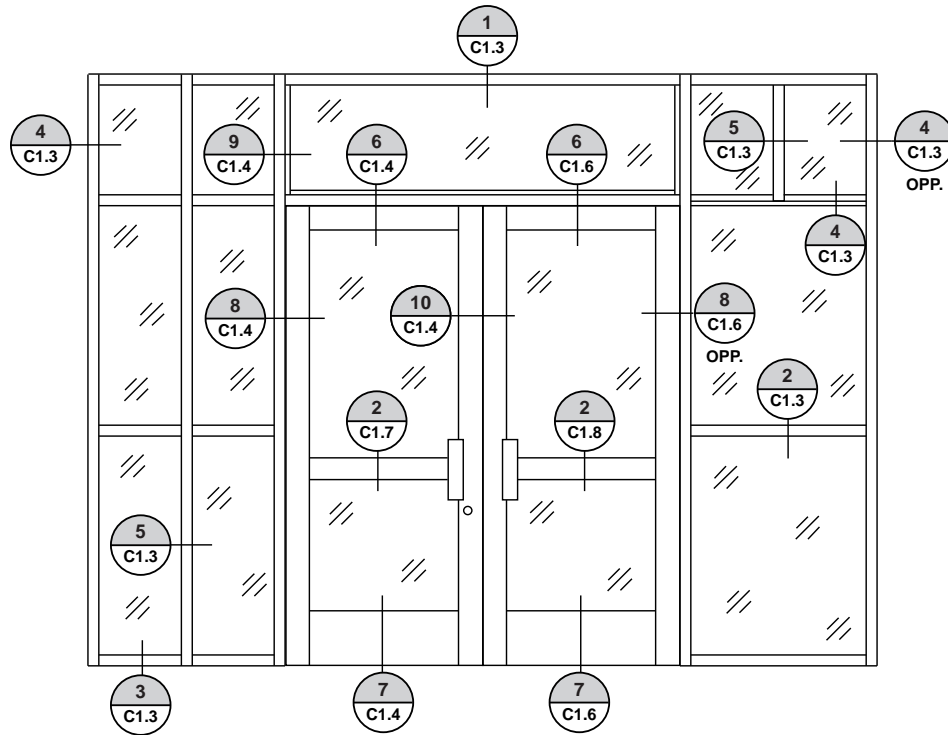

OFFSET HINGE DOORS

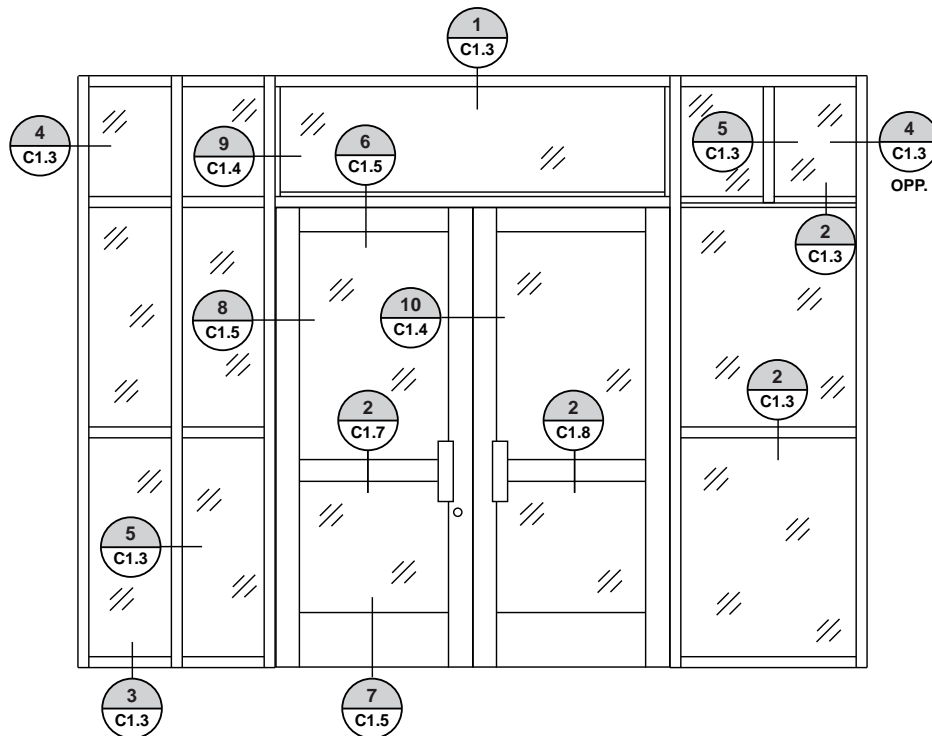

CENTER HINGE DOORS

REV. 1.0

TOLL FREE • 800-454-4304 PHONE • 425-483-6226 FAX • 425-486-7878

7533 WEST BOSTIAN ROAD WOODINVILLE, WASHINGTON 98072

ELEVATION

C1.2

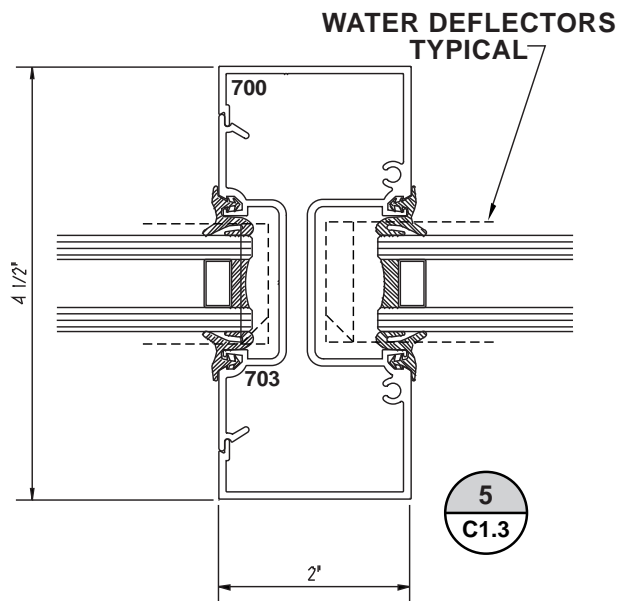
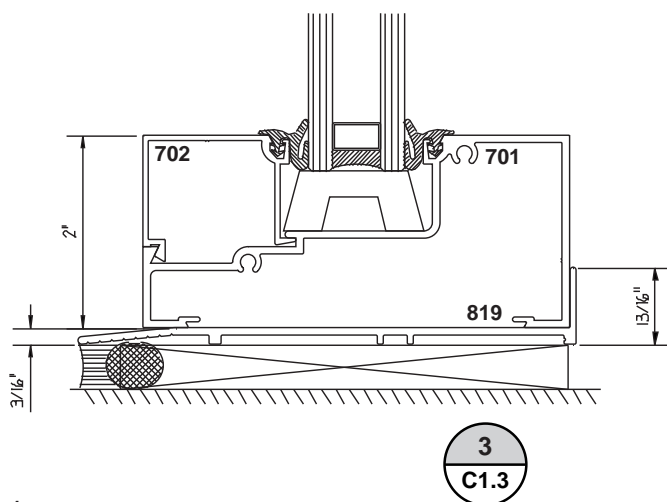
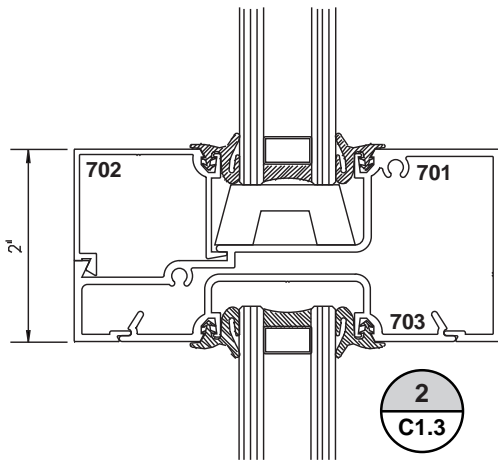
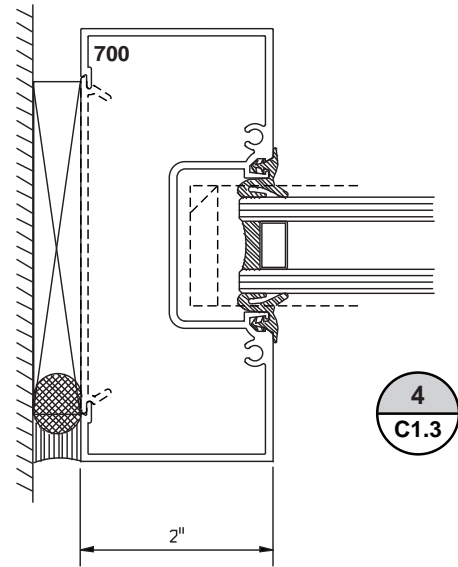
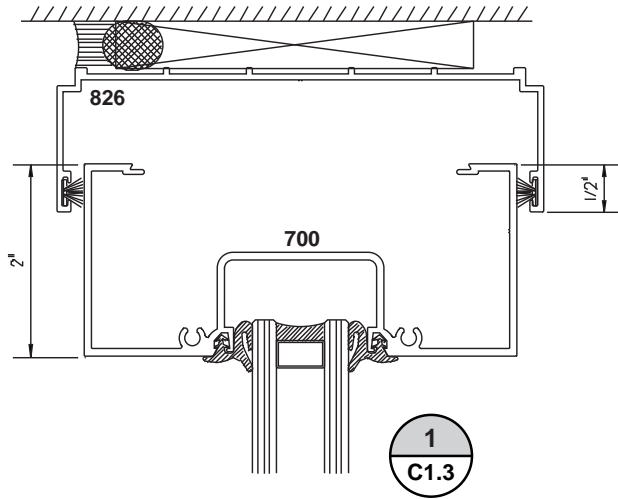

REV. 1.1

TOLL FREE • 800-454-4304 PHONE • 425-483-6226 FAX • 425-486-7878

7533 WEST BOSTIAN ROAD WOODINVILLE, WASHINGTON 98072

DETAILS

C1.3

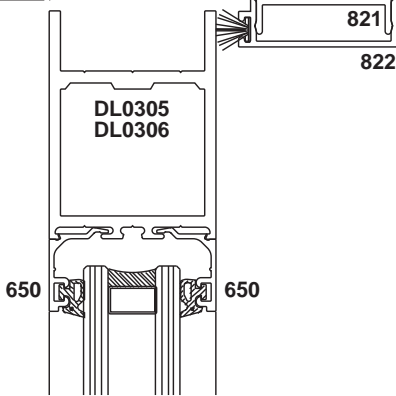
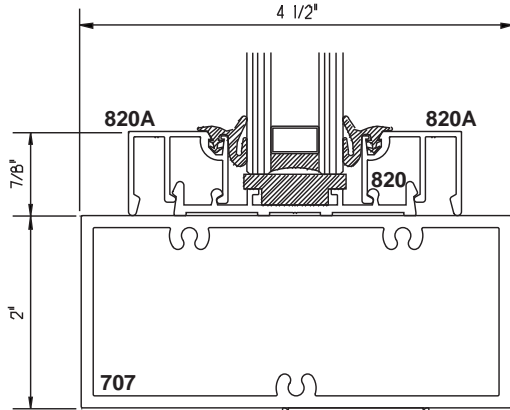

6
C1.4

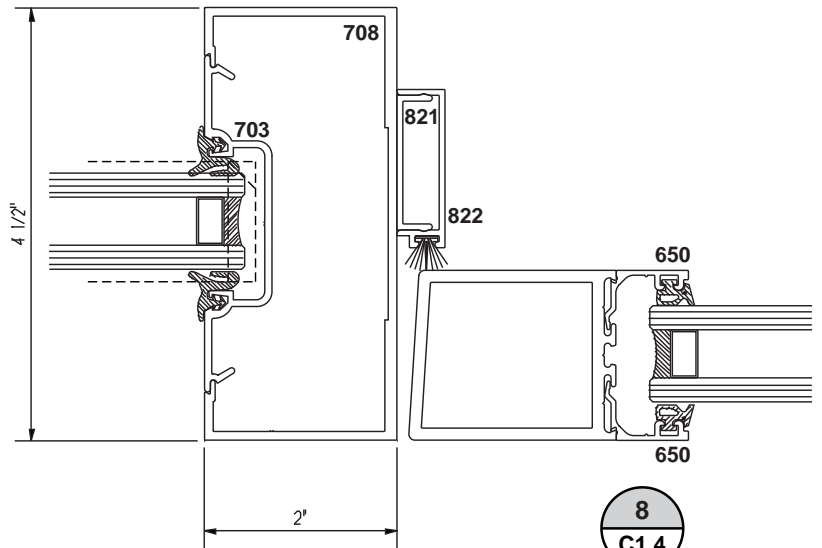

8
C1.4

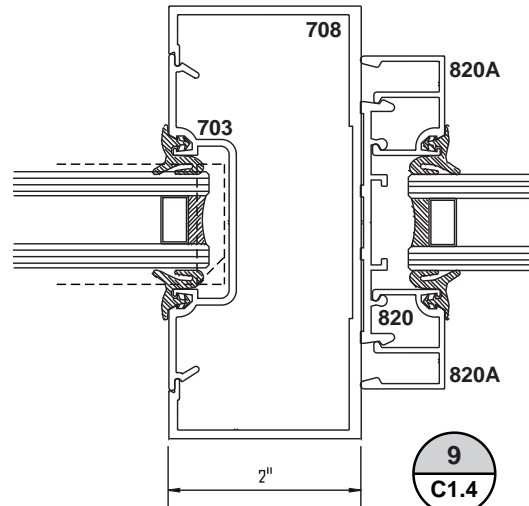

9
C1.4

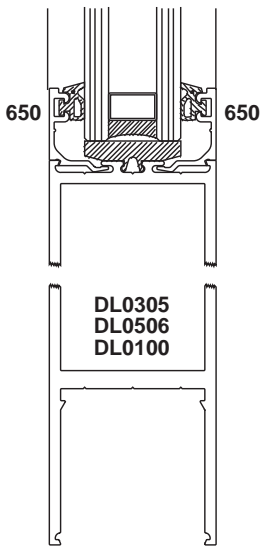

7
C1.4

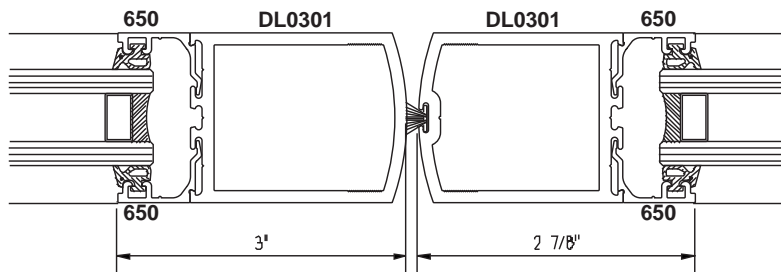

10
C1.4

REV. 1.1

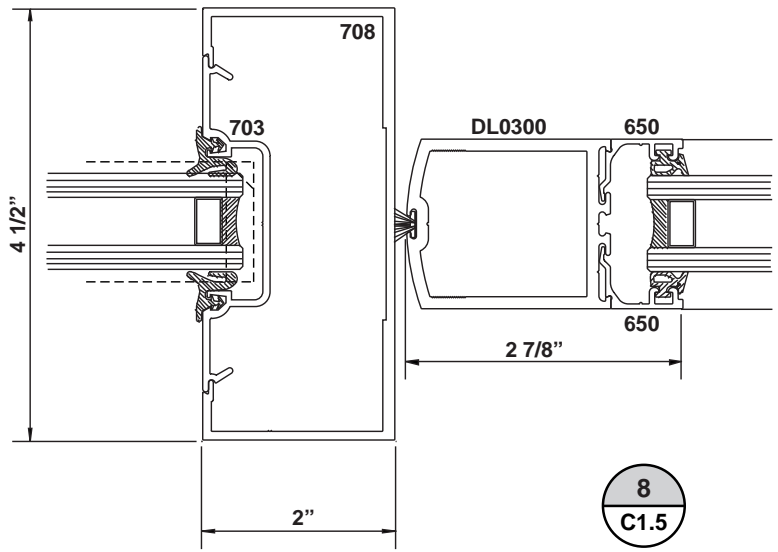
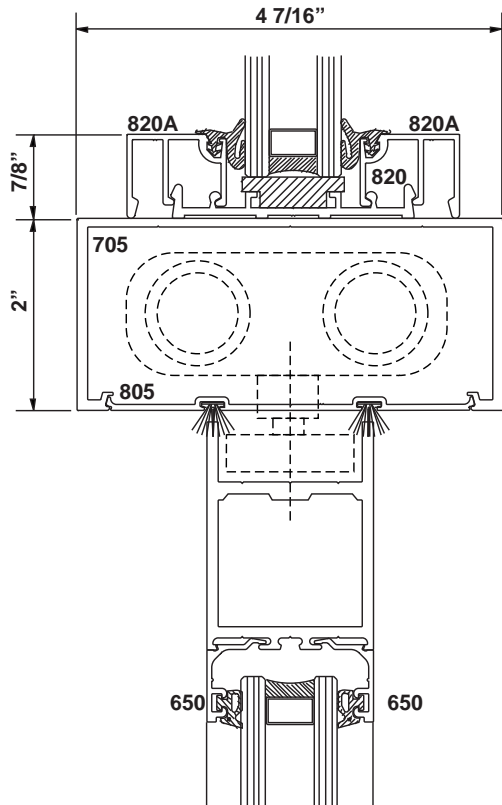

8
C1.5

6
C1.5

O.H.C.C. CENTER POINT

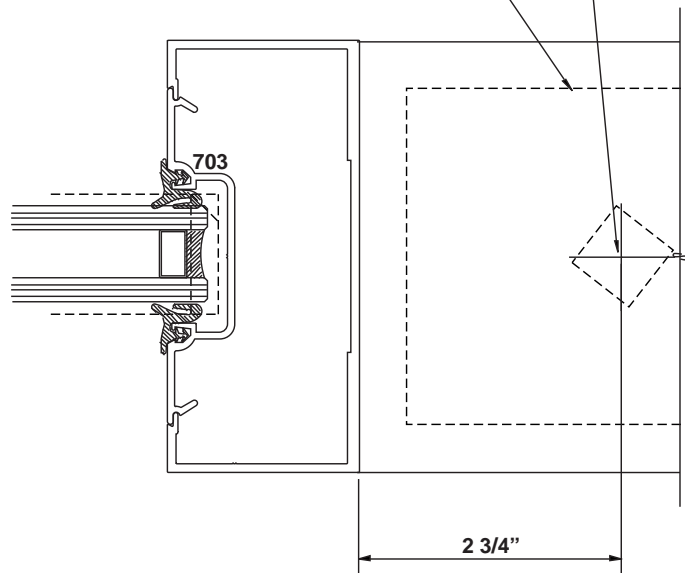
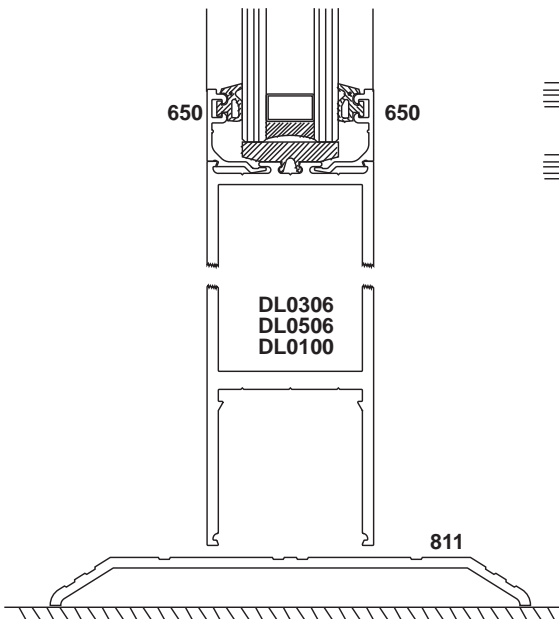

OVERHEAD VIEW

7
C1.5

REV. 1.1

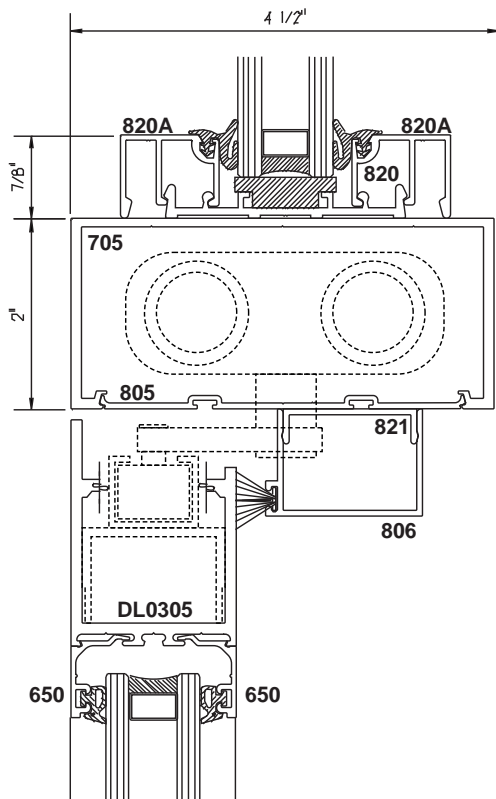

6
C1.6

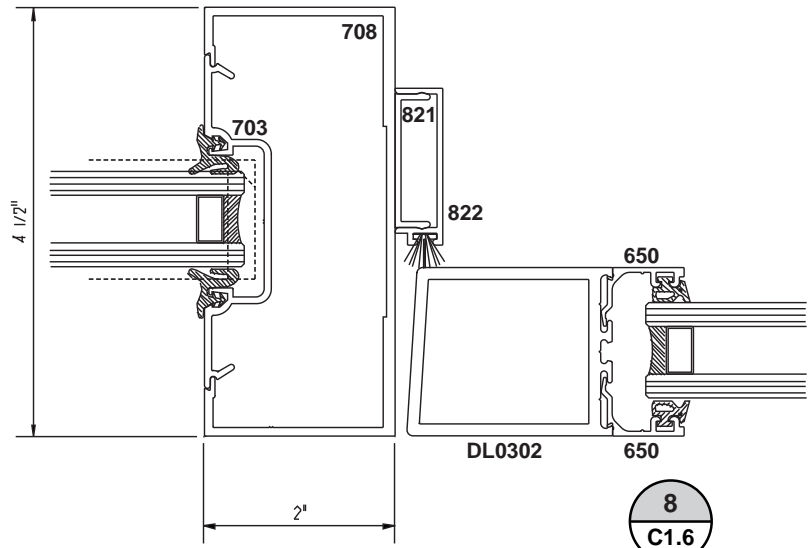

8
C1.6

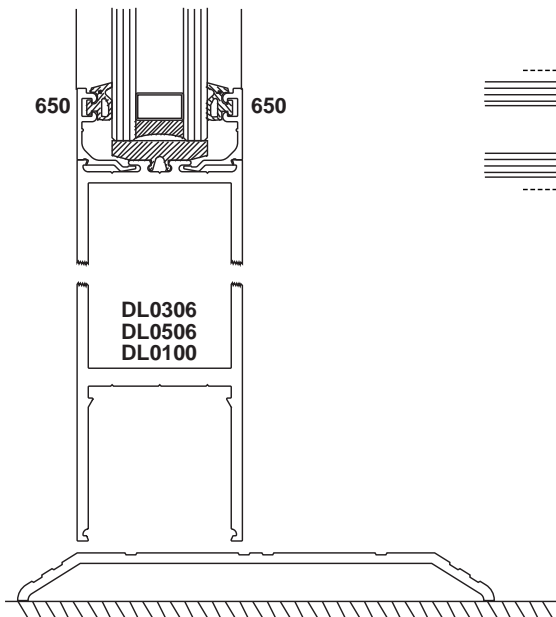

7
C1.6

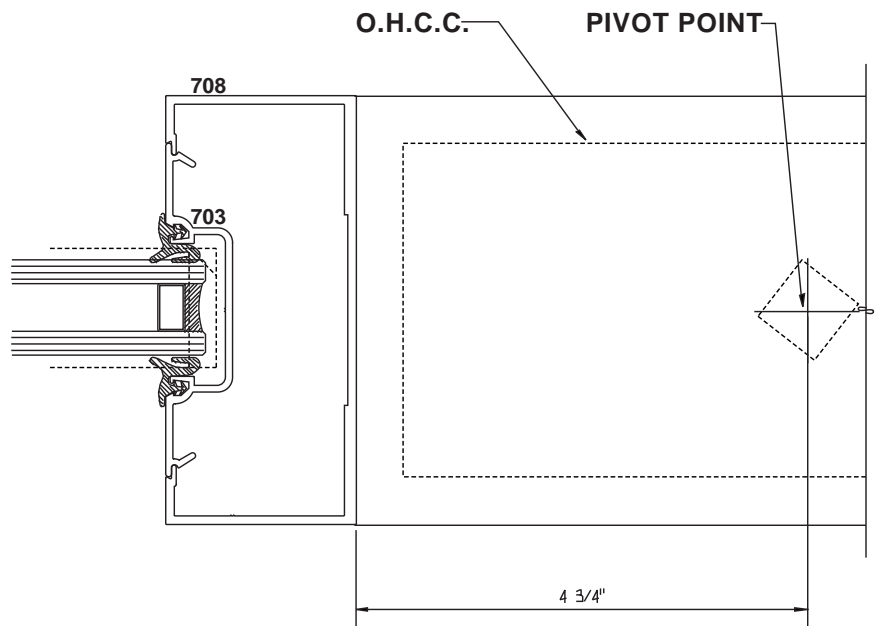

OVERHEAD VIEW

REV. 1.1



700 SYSTEM GLASS SIZES

TO DETERMINE & VERIFY GLASS SIZES FOR SIDELITES AND TRANSOMS,
USE THE FOLLOWING INFORMATION:

- 1) Determine the daylight opening of the side light
 - a) Add 3/4" to both the height & width of the daylight dimension.
 - b) This equals the actual net size of the glass needed.

- 2) Determine the day light opening of the transom (do not include the transom sash)
 - a) For width:
 - 1) Deduct 1" from width
 - 2) This equals the actual net width of the glass needed.

 - b) For height:
 - 1) No deductions are necessary from daylight
 - 2) The daylight equals the actual net height of the glass needed.